

ME224 Lab 3

Readings:

Chapter 6 (esp. 6.8, 6.9),
Lecture handouts.

Introduction:

In this lab you will learn some useful devices and circuits in electronics. Since the focus of this lab is on instrumentation, we are primarily concerned with using electronics for signal conditioning. In later labs we will focus on various transducers and cover any circuits specific to their application.

In signal conditioning we are taking the very weak electrical signal produced by the transducer and amplifying it so that it can be easily read by our data acquisition system. In addition to amplification, we are also trying to shift the signal in such a way that the Analog to Digital converters can make as accurate readings as possible.

IC Basics

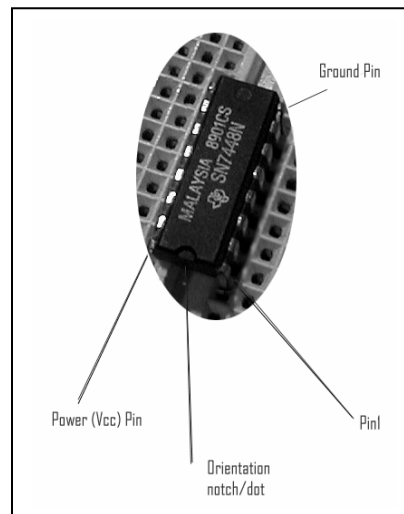

Figure 1. Chip schematic.

When working with Integrated Circuits or electronic chips in the lab there are a few characteristics that you should familiarize yourself with. First of all, in all schematics the electrical connections to the chip (called pins) are designated by number. You can determine the number of a pin by starting with pin 1 and counting counter clockwise. Pin 1 is designated on the physical chip by a small notch or dot on the chip. The first pin counterclockwise of the marker is Pin 1 (Figure 1).

Almost all IC's require a power and ground connection in addition to any inputs and outputs it may have and it's a common mistake for beginners to forget to hook these up. So the first step of troubleshooting a circuit that has IC's in it is to make sure the power and ground pins are properly connected. If you orient an IC so that the notch is up, the power pin is usually in the upper right and the ground pin is usually in the lower left. Each IC has a manufacturer data sheet associated with it. These data sheets can be found in reference manuals in the lab, or in adobe acrobat format on the manufacturer's web page.

The class web page has links to all the chips used in class ("Op-Amp LM741 info"). Keep in mind that it is standard practice to arrange the pins in an electrical schematic out of numerical order to produce cleaner drawings. Always refer to the manufacturers pin-out when assembling a circuit.

If you have a circuit that includes IC's and is not working, briefly touch all the chips. If a chip is too hot to touch, immediately turn off power to the circuit and check the IC. IC's that overheat like this are either broken or incorrectly wired. All IC's have a maximum operating temperature which can be learned by looking at the manufacturer's data sheet. The exception to the "too hot to touch" rule is if the IC is a transistor. Power transistors are capable of operating at high temperatures and may be operating correctly even if they are hot.

Finally, there are many differences between chips. The main categories are whether the chip is analog or digital and if it's digital, what type of transistor technology was used (TTL, CMOS, etc). As each new chip is introduced you will learn these differences.

Op-Amps

The most often used IC for signal conditioning is the Operational Amplifier. The op amp is a high performance linear amplifier. A mildly complex circuit that has been packaged as an Integrated Circuit for your ease of use. As a component it is a simple device. It amplifies the voltage difference between two input terminals. With just a few external components an op amp can be used to compare two voltages, amplify a signal by almost any power, oscillate, act as a filter, and many other things.

From your reading you should have a basic idea of how op amps work and the theory needed to design them into basic circuits. In this lab you will have a chance to build several op amp circuits and experiment with them. While the circuits you will build are pretty simple, you will gain some experience with trouble shooting circuits and using your instruments.

Notes before experiments:

- 1) *Be sure that settings of your probe attenuation factor to make the vertical scale readout correct and set to **10X** on your oscilloscope display menu (the factor value is written on your probe). Look at the page #86 of the oscilloscope manual.*
- 2) *All the resistors are to be chosen within the range: $1k\Omega$... $1M\Omega$.*
- 3) **Read the theory behind op amps, high and low pass filters.**
- 4) **Read an oscilloscope manual.**

Activity 3.1

Objective: Build a simple non-inverting op amp and observe its operation.

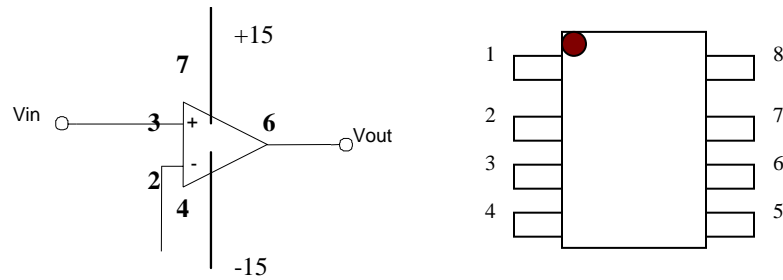

Figure 2. Connections of an op-amp

The Figure 2 will help you to connect your op-amp to the amplifier circuit you are going to design according to the Appendix A schematics. Numbers written in bold in the Figure 2 correspond to the pin numbers of the op-amp (look at the class web-site for reference on the op-amp connections). +15 and -15 are the voltages which power your op-amp (use the electric board for it).

Procedure:

Record your measurements on the answer sheet.

1. Build circuit 3.1.a. Set the function generator to generate the input signal of 2 V_{p-p} at 500Hz.
2. Measure the exact voltage range of the input signal. Record this value on your answer sheet. Also measure the exact values of your resistors.
3. Calculate the output and then measure the output.
4. Change the feedback resistance to 22K. Calculate the output and then measure the output.
5. Design a non-inverting amplifier that will have a gain of 2.15. Record the theoretical values for R₁ & R₂ on the answer sheet.
6. Build and test the circuit. Record the actual values of V_{in}, R₁, R₂, V_{out}, and A_v.

Analysis:

Take note of the real values of the components versus the theoretical values. Try to get a sense of how sensitive the circuit is to the normal variance of the components.

Activity 3.2

Objective: Build a simple inverting op amp and observe its operation.

Procedure:

Record your measurements on the answer sheet.

1. Build circuit 3.2. Set the function generator to generate the input signal of 2 V_{p-p} at 500 Hz.
2. Measure the exact voltage range of the input signal. Record this value on your answer sheet. Also measure the exact values of your resistors.

3. Calculate the output and then measure the output.
4. Use both channels of your oscilloscope to view the inversion of the signal. (Hook one probe to the signal source and the other to the op amp output.)
5. Design an inverting amplifier that will take $+5V_{DC}$ from your power supply and convert it to $-7.8V_{DC}$. Record the theoretical values for R_1 & R_2 on the answer sheet.
6. Build and test the circuit. Record the actual values of V_{in} , R_1 , R_2 , V_{out} , and A_v .

Analysis:

The second channel of your oscilloscope (see “Oscilloscope tutorial” on the course web-page) is very handy for comparing two signals. If you have not already, take some time to read about dual channel math in the oscilloscope manual (see “Oscilloscope tutorial” on the course web-page).

Activity 3.3

Objective: Build a simple summing op amp and observe its operation.

Procedure:

Record your measurements on the answer sheet.

1. Build circuit 3.3. Set the function generator to generate the input signal of 2 V_{p-p} at 500Hz to use as V_1 and use the variable voltage output on the bench power supply for V_2 (set to +5V initially).
2. Set one probe of your oscilloscope to track the output and the other to track the input DC signal.
3. Calculate the output and then measure the output.
4. Vary the DC signal, what happens to the output?

Analysis

This circuit will average the signals if you set the gain correctly. For instance, if you have three input voltages each to a same valued resistor, you want to find a value for the feedback resistor such that R_1/R_2 equals 1/3.

Activity 3.4

Objective: Build a simple difference op amp and observe its operation.

Procedure:

Record your measurements on the answer sheet.

1. Build circuit 3.4.
2. Calculate the output you expect to see and record the resistor values.
3. Measure the actual output.
4. *Design a circuit to take a 2.5V_{pp} 60Hz sin wave with a DC offset of 2.5 volts and shift it to 10V_{pp} centered about zero volts.*
5. Build and test the circuit. Record the actual values of V_{in} , R_1 , R_2 , V_{out} , and A_v .

Filters

Filters are circuits that remove some set of frequencies from a signal. For instance, your stereo system uses filters to isolate the bass and treble frequencies for amplification by

the equalizer. None of the transducers we are working with output a signal as complex as a sound waveform, but filters can be useful because many transducers are susceptible to electrical interference and filters can help remove this interference.

Activity 3.5

Objective: Build a low pass filter and observe it's operation.

(Low pass filter removes high frequency from your signal allowing low frequency to pass through. By looking at the signal shape on your oscilloscope you will be able to see if your circuit can let low frequency signal pass through).

Procedure:

Record your measurements on the answer sheet.

1. Build circuit 3.5. Set the function generator to generate the input signal of 1 Vp-p at 100 Hz.
2. While observing the output and input signals with both channels of the oscilloscope, increase the input signal frequency in 200Hz increments. Maintain a constant input signal of 1 Vp-p. You will have to adjust the amplitude of the signal everytime you change the frequency.
3. Record the output voltage for each frequency until the output voltage levels drop to 0.707 of it's value at 100Hz.
4. Using the data gathered in the previous step, draw the frequency response curve for your circuit. Mark the cutoff frequency – 0.707 or 3dB “down” point.

Remarks:

(1.A system will usually have two frequencies at which attenuation of the system is – 3dB. They are defined as the low and high corner or *cut-off frequencies*. These two frequencies define the bandwidth of the system. The term bandwidth of a system is defined as the range of frequencies the system can adequately reproduce.

2. Frequency response curve is a plot of voltage ratio (V_{out}/V_{in}) versus frequency.)

Analysis:

You can see that this circuit removes the high frequency component of a signal.

Activity 3.6

Objective: Build a high pass filter and observe it's operation.

Procedure:

Record your measurements on the answer sheet.

1. Build circuit 3.6. Set the function generator to generate the input signal of 1 Vp-p at 100 Hz.
2. While observing the output and input signals with both channels of the oscilloscope (*see “Oscilloscope tutorial” on the course web-page*), increase the input signal frequency in 200Hz increments. Maintain a constant input signal of 1 Vp-p. You will have to adjust the amplitude of the signal everytime you change the frequency.
3. Record the output voltage for each frequency until the output voltage no longer increases in amplitude as frequency increases.

4. Using the data gathered in the previous step, draw the frequency response curve for your circuit. Mark the cutoff frequency – 0.707 or 3dB “down” point.

APPENDIX A: Circuit Diagrams

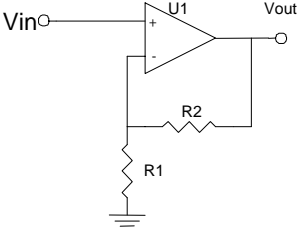
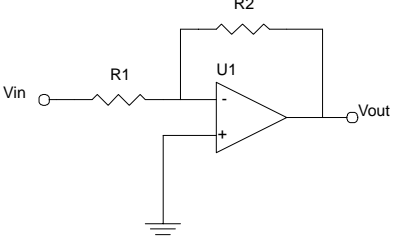
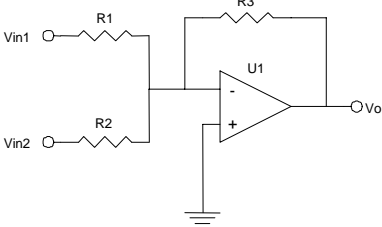
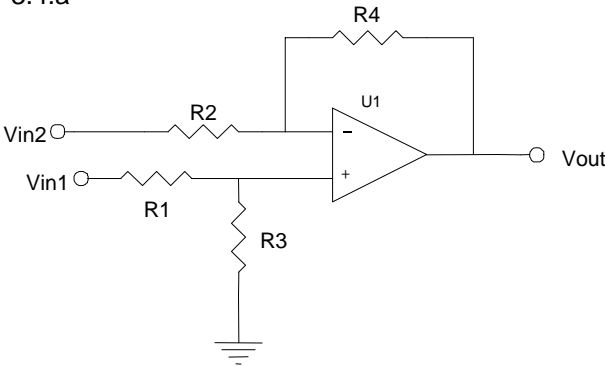
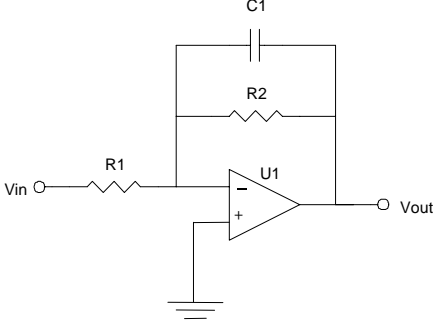
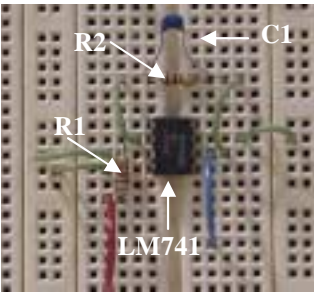
Circuit Diagram	BOM	Governing Equation
<p>3.1.a</p> 	<p>Vin: 2V_{p-p} 500Hz U1: LM741 R1,R2: 10KΩ</p>	$\frac{V_{out}}{V_{in}} = 1 + \frac{R_2}{R_1}$
<p>3.2.a</p> 	<p>Vin: 2V_{p-p} 500Hz U1: LM741 R1,R2: 10KΩ</p>	$\frac{V_{out}}{V_{in}} = -\frac{R_2}{R_1}$
<p>3.3.a</p> 	<p>Vin: 2V_{p-p} 500Hz U1: LM741 R1,R2,R3: 10KΩ</p>	<p>$V_{out} = -R_3 \cdot \left(\frac{V_{in1}}{R_1} + \frac{V_{in2}}{R_2} \right)$</p>
<p>3.4.a</p> 	<p>Vin: 2V_{p-p} 500Hz U1: LM741 R1,R2: 10KΩ R3, R4: 10KΩ</p>	<p>If $R_1=R_2=R$; $R_3=R_4=R_F$</p> $V_{out} = \frac{R_F}{R} (V_1 - V_2)$
<p>3.5.a</p> 	<p>Vin: 2V_{p-p} 500Hz U1: LM741 R1: 1KΩ R2: 10KΩ C1: 0.01μF</p>	

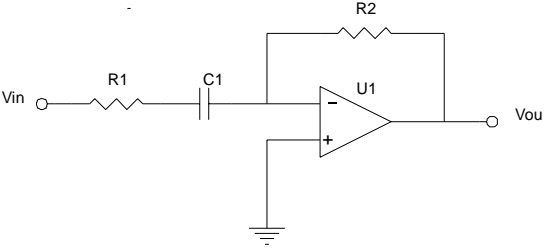
Circuit Diagram	BOM	Governing Equation
 <p>3.6.a</p>	<p> V_{in}: 2V_{p-p} 500Hz U1: LM741 R1: 1KΩ R2: 10KΩ C1: 0.068μF </p>	

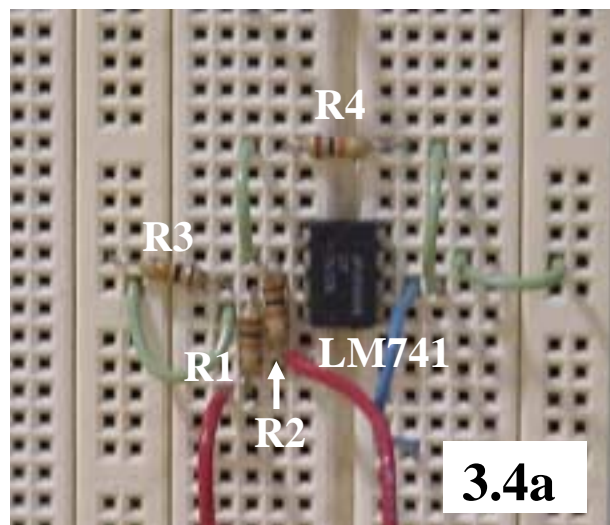
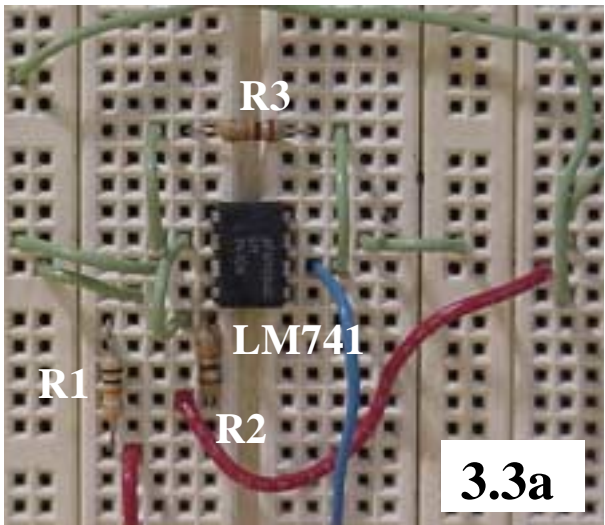
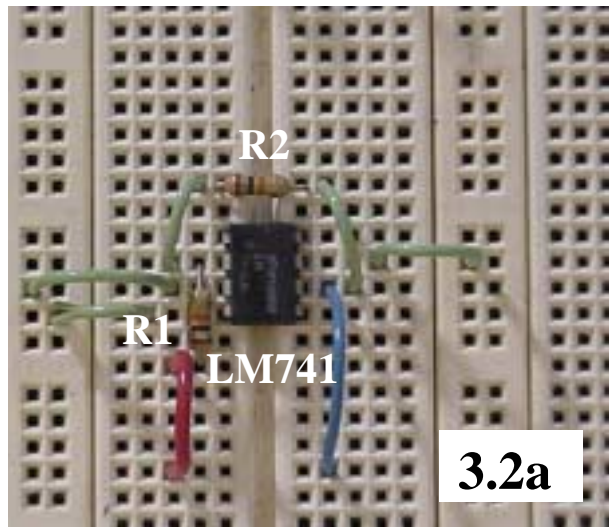
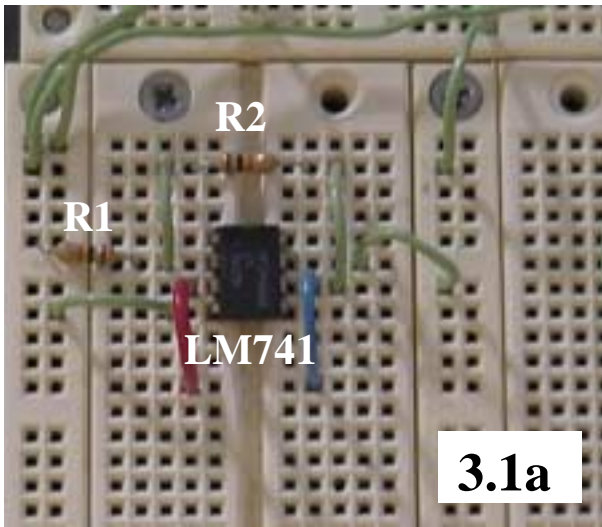

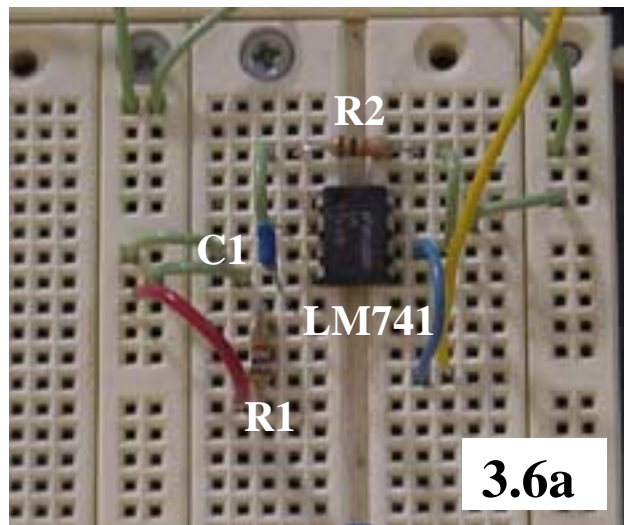
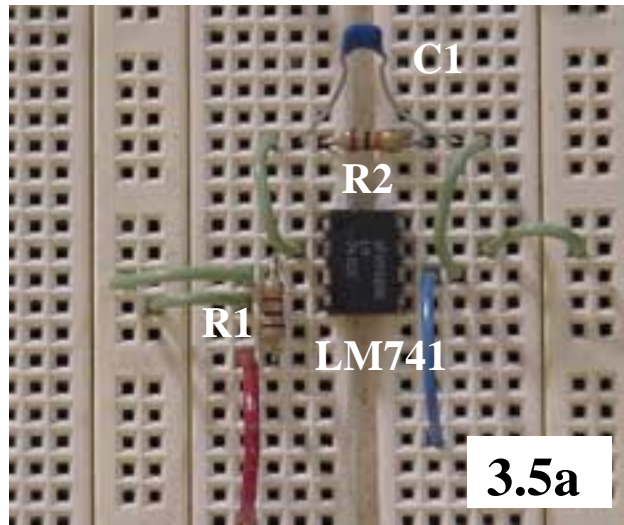

Appendix 2 – Answer sheet

Activity 3.1

1. n/a
2. V_{p-p} _____ R_1 _____ R_2 _____
3. $V_{out\ calc}$ _____ $V_{out\ meas.}$ _____
4. $V_{out\ calc}$ _____ $V_{out\ meas.}$ _____
5. V_{in} _____ R_1 _____ R_2 _____ V_{out} _____ A_v _____
6. V_{in} _____ R_1 _____ R_2 _____ V_{out} _____ A_v _____

Activity 3.2

1. n/a
2. V_{p-p} _____ R_1 _____ R_2 _____
3. $V_{out\ calc}$ _____ $V_{out\ meas.}$ _____
4. n/a
5. V_{in} _____ R_1 _____ R_2 _____ V_{out} _____ A_v _____
6. V_{in} _____ R_1 _____ R_2 _____ V_{out} _____ A_v _____

Activity 3.3

1. n/a
2. $V_{out\ calc}$ _____ $V_{out\ meas.}$ _____
3. _____

Activity 3.4

1. n/a
2. $V_{out\ calc}$ _____ R_1 _____ R_2 _____
3. $V_{out\ meas.}$ _____

Activity 3.5

Frequency	Output voltage – V_{p-p}

Activity 3.6

Frequency	Output voltage – V_{p-p}

